

# OIL FREE PISTON COMPRESSOR OF SERIES



**In order to supply our generators with compressed air , we have chosen a range of silent, without oil easy to service compressors , ideal for laboratory applications**

OF Compressors are non lubricated pistons, they thus work without oil, they also present the lowest, sound low level of the market, as well as are reliability and have a better life expectancy.

The range proposed high quality compressors, flow rate varied from 20 to 260 L / min. Several models are associated with reservoirs which has capacity evolving between 4 and 40 L.

They are quite, specially dedicated to the demanding applications of laboratory.



## Benefits

- \* OF Series compressors offer **high reliability and long life expectancy** due to their technological choices : unique cooling system - ultra resistant piston rings and segments.
- \* These **Oil-free compressors** ensure the production of clean air to meet the constraints of laboratory applications.
- \* A full range of compressor which having a good **flexibility for installation and use**, particularly in cases of integration of existing facilities.  
Different outlet port, adjustable feet, several mounting options.
- \* Tanks lined with a **corrosion protection** ensures high hygienic air quality throughout the life of the reservoir.

## Standard Features

Piston compressor, **without oil and silent.**

**Noise level and vibration** very low.

**Flow rate** : 38 L/min to 180 L/min with a maximum pressure of 8 or 10 bar according to models.

Some models are built in **soundproof and ventilated box**, in order to be installed into the laboratory.

An **automatic drain** is fit in standard on the soundproof models and is in option for the others

**Outlet connection:** ¼ G

**Routine maintenance minimal** : air inlet filter every 2000h, non-return valve and 5 µm filter every 4000h.  
The maintenance on the motor is recommended every 8000 functioning hours. Please contact us for this operation.

# OIL FREE PISTON COMPRESSOR OF SERIES

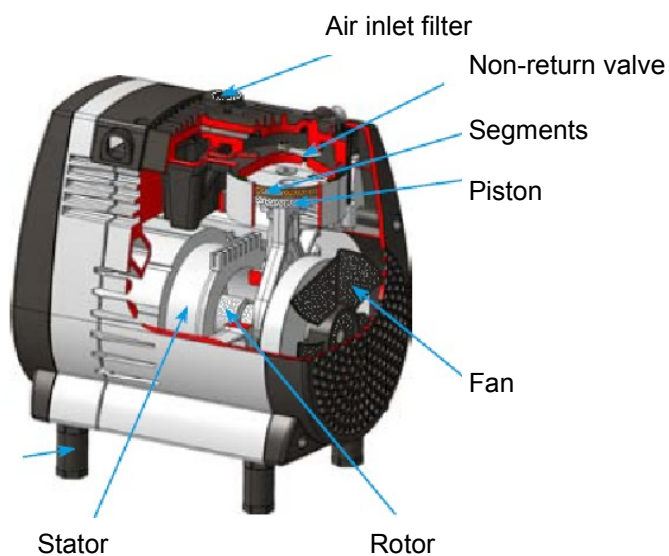

OF301 and OF302 Series

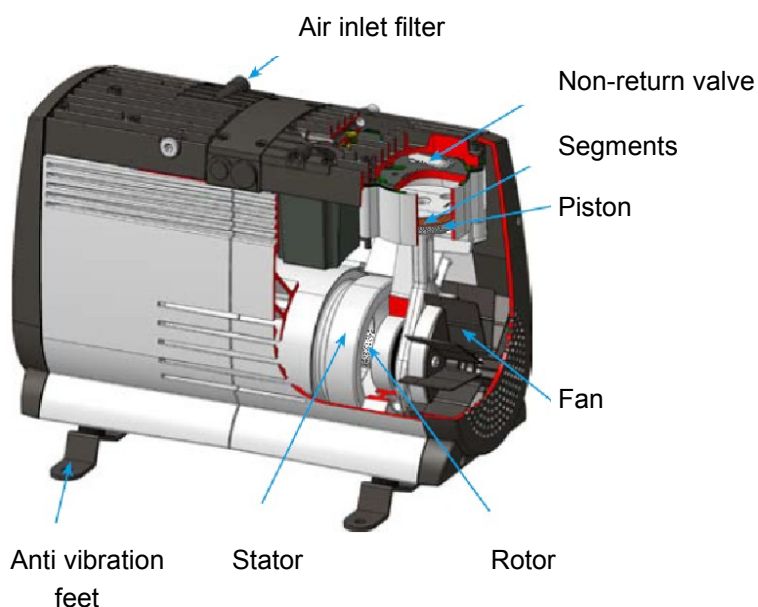

OF1201 and OF1202 Series

## Technical Specifications

Model	OF301-4B	OF301-4M	OF302-4B	OF302-4M	OF302-25B	OF302-25M	2xOF302-40M	OF1201-25M	OF1202-40M	2xOF1202-40M
flowrate (L/min)	20		38			76	65	130	260	
Max pressure	10 bar									
Noise level	65	47	65	47	65	47	50	58	60	63
Reservoir Capacity	4L				25		40	25	40	
soundproof box and automatic drain	NO	YES	NO	YES	NO	YES	YES	YES	YES	YES
Connections	G 1/4" (BSP) Female									
Weight kg	19	37	22	45	28	78	107	88	116	162
Dimensions (H, W, D) mm	39x31x35	76x46x42	39x32x35	76x46x42	38x38x61	76x46x86	67x65x86	72x46x86	72x65x86	72x78x86



**F-DGS**

8-10 RUE DU BOIS SAUVAGE - BATIMENT Q18 - 91000 EVRY - FRANCE

Tel: +33 (0)1.64.98.21.00 - Fax: +33 (0)1.64.98.00.43

E-mail : [info@f-dgs.com](mailto:info@f-dgs.com) - Site : [www.f-dgs.com](http://www.f-dgs.com)